

1. Check the meter. Only mount a meter without damage.

NOTE: The housing is sealed, do not open the meter!

No warranty if the housing is opened or the seal is removed.

This meter is delivered without protection covers for wiring.

2. Safety precautions



Caution

- Turn off and if possible lock all sources supplying the energy meter and the equipment that is connected to it before working on it.
- Always use a properly rated voltage sensing device to confirm that power is off.
- The connecting wire, connecting the device to the outside circuit, should be sized in accordance with local regulations for the maximum amount of the current breaker or other overcurrent protection devices used in the circuit.
- An external switch or a circuit-breaker should be installed on the supply wires, which will be used to disconnect the meter and the device supplying energy. It is recommended that this switch or circuit-breaker is placed near the meter because that is more convenient for the operator. The switch or circuit-breaker should comply with the specifications of the building's electrical design and all local regulations.
- An external fuse or thermal cut-off used as an overcurrent protection device for the meter must be installed on the supply side wires. It's recommended that this protection device is also placed near the meter for the convenience of the operator. The overcurrent protection device should comply with the specifications of the building's electrical design and all local regulations.



Warning

- The installation should be performed by qualified personnel familiar with applicable codes and regulations.
- Use insulated tools to install the device. A fuse, thermal cut-off or single-pole circuit breaker should be fitted on the supply line and not on the neutral line.
- The meter is intended to be installed in a Mechanical Environment 'M1', with Shock and Vibrations of low significance and Electromagnetic Environment 'E2', as per 2014/32/EC Directive. The meter is intended for indoor use. The meter shall be installed inside a suitable IP rated enclosure, in accordance with local codes and regulations.
- To prevent tampering, an enclosure with a lock or a similar device can be used.
- The meter has to be installed against a fire resistant wall.
- The meter has to be installed in a well-ventilated and dry place.
- The meter has to be installed in a protective box if the meter is exposed to dust or other contaminants.
- The meter can be installed and used after being tested and can be sealed afterwards.
- The device can be installed on a 35mm DIN rail.
- The meter should be installed on a location where the meter can be read easily.
- In case the meter is installed in an area with frequent surges for example due to thunderstorms, welding machines, inverters etc., the meter is required to be protected with a Surge Protection Device.
- The device should be sealed immediately after installing it in order to prevent tampering.
- The device should be installed with a torque screw driver.

This user manual does not contain every applicable safety regulation for using this meter. Also it might be required because of company, local government regulations or (inter)national laws to take additional measures. We have checked the contents of this manual and every effort has been made to ensure that the descriptions are as accurate as possible. However, deviations from the description cannot be completely ruled out, so that no liability can be accepted for any errors or omissions in the information given. Versions might be different in default programming based on the customers order.

3. Specifications

Nominal voltage (Un)	230/400V AC (3~)
Operational voltage	3*230/400V ±20%
Input power supply	12VDC, 100mA
Primary current	80A (CT)
Secondary current	40mA
Operational current range	0,4%Ib-Imax
Operational frequency range	50Hz
Internal power consumption	≤2W/Phase - ≤10VA/Phase (active - reactive)
Operating temperature	-25°C - +55°C
Accuracy class	1
Communication	Modbus RTU - RS485
Modbus ID	1~247
Modbus baud rate	9600 / 19200
Modbus parity	Even / None / Odd
Combination code total energy	01: forward only / 04: reverse only / 05: forward + reverse / 06: reverse - forward / 09: forward - reverse / 10: forward - reverse

4. Dimensions

Height without protection cover	92,4 mm
Width	70 mm
Depth	63 mm
Max. diameter power connection wires	7,3 mm
Weight N380 including three CT's	370 gr

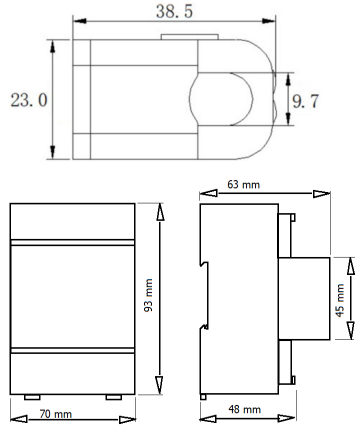

This meter has a current transformer (CT) to measure the direct current (DC).

The CT cannot be replaced with another CT

5. Connection diagram (3P4W)

L1	-	UL1	<u>PULSE</u>	
L2	-	UL2	18-	S0-
L3	-	UL3	19-	S0+
N	-	Neutral		
10	-	CT in	<u>MODBUS RS485</u>	
11	-	CT out	20-	-
			21-	GND
12	-	CT in	22-	A
13	-	CT out	23-	B
14	-	CT in	<u>POWER</u>	
15	-	CT out	24-	12V
			25-	GND

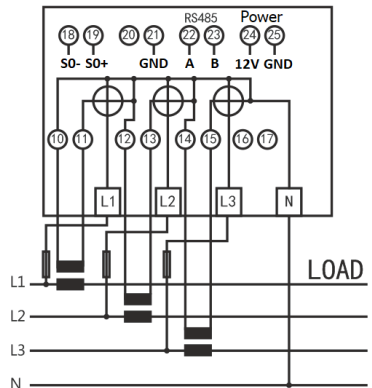



6. Default settings

Modbus

Baud rate 9600
Parity Even
Modbus ID 01

Combination code C05 (forward + reverse)

7. Certificate

	We, Inepro Metering BV <small>(supplier's name)</small>
	Pondweg 7 2153 PK Nieuw-Vennep The Netherlands <small>(supplier's address)</small>
	declare under our sole responsibility that the product: N1-CT Single phase DIN rail Watt Hour meter <small>(Name, type or model, batch or serial number, possibly source and number of items)</small>
	<small>This declaration of Conformity is suitable to the European Standard EN 45014 General Criteria for Supplier's Declaration of Conformity. The basis for the criteria has been found in international documentation, particularly in ISO / IEC Guide 22. For information on manufacturer's Declaration of Conformity with standards or other technical specifications</small>
	<small>to which this declaration relates in conformity with the following European harmonized and published standards at date of this declaration:</small> EN 62368-1:2014+A11:2017 EN 62053-23:2003+A1:2017 EN 62052-11:2003+A1:2017 EN 62053-21:2003+A1:2017
	<small>(Title and/or number and date of issue of the applied standard(s))</small> Following the provisions of the Directives (if applicable): -2014/55/EU -2014/30/EU
	Nieuw-Vennep, 2022, June 27nd <small>Place and date of issue</small>
	D. van der Vaart <small>Name of responsible for CE-marking</small>

8. Website

Scan the QR-code to visit our website

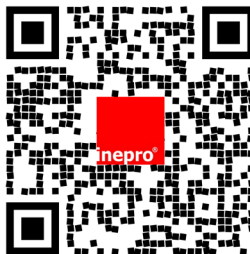

8. Modbus register file

Register	Content	Function	R/W	Length	Data Type	Unit
4000	Serial number	03	Read	2	signed	-
4002	Meter code	03	Read	1	signed	-
4003	Meter ID (Mbus/Modbus)	03	Read	1	signed	-
4004	Baud Rate	03	Read	1	signed	-
4005	Protocol Version	03	Read	2	Float - (ABCD)	-
4007	Software Version	03	Read	2	Float - (ABCD)	-
4009	Hardware Version	03	Read	2	Float - (ABCD)	-
400B	Meter Amps	03	Read	2	signed	A
4011	Parity setting	03	Read	1	signed	-
401B	Software version(CRC)	03	Read	2	signed	-
400F	Combination code	03	Read	1	Signed	-

Register	Content	Function	Read	Length	Data Type	Unit
5000	Voltage	03	Read	2	Float - (ABCD)	V
5002	L1 Voltage	03	Read	2	Float - (ABCD)	V
5004	L2 Voltage	03	Read	2	Float - (ABCD)	V
5006	L3 Voltage	03	Read	2	Float - (ABCD)	V
5008	Grid Frequency	03	Read	2	Float - (ABCD)	Hz
500A	Current	03	Read	2	Float - (ABCD)	A
500C	L1 Current	03	Read	2	Float - (ABCD)	A
500E	L2 Current	03	Read	2	Float - (ABCD)	A
5010	L3 Current	03	Read	2	Float - (ABCD)	A
5012	Total Active Power	03	Read	2	Float - (ABCD)	kW
5014	L1 Active Power	03	Read	2	Float - (ABCD)	kW
5016	L2 Active Power	03	Read	2	Float - (ABCD)	kW
5018	L3 Active Power	03	Read	2	Float - (ABCD)	kW
501A	Total Reactive power	03	Read	2	Float - (ABCD)	kVA
501C	L1 Reactive power	03	Read	2	Float - (ABCD)	kVA
501E	L2 Reactive power	03	Read	2	Float - (ABCD)	kVA
501C	L3 Reactive power	03	Read	2	Float - (ABCD)	kVA
5022	Total Apparent Power	03	Read	2	Float - (ABCD)	KVA
5024	L1 Apparent Power	03	Read	2	Float - (ABCD)	KVA
5026	L2 Apparent Power	03	Read	2	Float - (ABCD)	KVA
5028	L3 Apparent Power	03	Read	2	Float - (ABCD)	KVA
502A	Power Factor	03	Read	2	Float - (ABCD)	-
502C	L1 Power Factor	03	Read	2	Float - (ABCD)	-
502E	L2 Power Factor	03	Read	2	Float - (ABCD)	-
5030	L3 Power Factor	03	Read	2	Float - (ABCD)	-

Register	Content	Function	Read	Length	Data Type	Unit
6000	Total Active Energy	03	Read	2	Float - (ABCD)	kWh
6006	L1 active Energy	03	Read	2	Float - (ABCD)	kWh
600C	Forward Active Energy	03	Read	2	Float - (ABCD)	kWh
6018	Reverse Active Energy	03	Read	2	Float - (ABCD)	kWh

Write

Register	Content	Function	Length	Unit
4003	Modbus ID	06	0001	01-147 - 01 Default - 00 Broadcast
Command:	01 06 4003	000A (new ID: 10)		
4004	Baud Rate	06	0001	300 (012C) - 600 (0258) - 1200 (04B0)- 2400 (0960)- 9600 (2580)
Command:	01 06 4004	2580 (new Baudrate: 9600)		
4011	Parity	06	0001	01 - Even, 02 - None, 03 - Odd
Command:	01 06 4011	0002 (new Parity: None)		
400F	Combination	06	0001	01, 04, 05, 06, 09, 10, 11
Command:	01 06 400F	000A (new Comb. Code: 10)		